

# Global Modeling of Spatially Distributed Microwave and Millimeter-Wave Systems

Michael B. Steer, *Fellow, IEEE*, James F. Harvey, *Member, IEEE*, James W. Mink, *Fellow, IEEE*, Mostafa N. Abdulla, *Student Member, IEEE*, Carlos E. Christoffersen, *Student Member, IEEE*, Hector M. Gutierrez, *Member, IEEE*, Patrick L. Heron, *Member, IEEE*, Chris W. Hicks, *Student Member, IEEE*, Ahmed I. Khalil, *Student Member, IEEE*, Usman A. Mughal, *Student Member, IEEE*, Satoshi Nakazawa, *Student Member, IEEE*, Todd W. Nuteson, *Member, IEEE*, Jae Patwardhan, *Member, IEEE*, Steven G. Skaggs, *Member IEEE*, Mark A. Summers, *Member, IEEE*, Shunmin Wang, and Alexander B. Yakovlev, *Member, IEEE*.

**Abstract**— Microwave and millimeter-wave systems have generally been developed from a circuit perspective with the effect of the electromagnetic environment modeled using lumped elements or  $N$ -port scattering parameters. The recent development of the local reference node concept coupled with steady-state and transient analyses using state variables, allows the incorporation of unrestrained electromagnetic modeling of microwave structures in a circuit simulator. A strategy implementing global modeling of electrically large microwave systems using the circuit abstraction is presented. This is applied to the modeling of a quasi-optical power combining amplifier.

**Index Terms** — Microwave circuits, circuit field interaction, electromagnetic analysis, global modeling, method of moments, nonlinear analysis, circuit theory

## I. INTRODUCTION

The almost overwhelming use of abstraction in electronic engineering has enabled the design of surprisingly complex systems. Electrical engineers are so comfortable with the circuit abstraction that few pause to realize its significance and the constraints that it imposes on modeling the physical world. One viewpoint is that a circuit — of say resistors, inductors and capacitors — is a graphical way of specifying the coupling of first order algebraic ( $I = V/R$ ),

This work was supported by the Defense Advanced Research Projects Agency (DARPA) through the MAFET Thrust III program as DARPA agreement number DAAL01-96-K-3619 and by a Multidisciplinary University Research Initiative (MURI) sponsored by the U.S. Army Research Office through a contract with Clemson University.

M. B. Steer was with the Department of Electrical and Computer Engineering, North Carolina State University (NCSSU), Raleigh, NC 27695-7914. He is now with the Institute of Microwaves and Photonics, School of Electronic and Electrical Engineering, The University of Leeds, Leeds, LS2 9JT, United Kingdom, email: m.b.steer@ieee.org

J. F. Harvey is with the United States Army Research Office, PO Box 12211, Research Triangle Park, North Carolina, 27709, U.S.A.

J. W. Mink, C. E. Christoffersen, M. N. Abdullah, H. M. Gutierrez, C. W. Hicks, A. I. Khalil, U. Mughal, S. Nakazawa, S. Wang and A. B. Yakovlev are with NCSU.

P. L. Heron, T. W. Nuteson, J. Patwardhan, S. G. Skaggs and M. A. Summers were with NCSU. P. L. Heron and M. A. Summers are now with Cadence Design Systems Analog and Mixed Signal Design Center, 200 Regency Forest Drive, Suite 260, Cary, North Carolina, 27511, U.S.A.. T. W. Nuteson is now with the Aerospace Corporation, Mail Station: CH1-420 15049 Conference Center Drive, Suite 600, Chantilly, Virginia 20151, U.S.A. J. P. Patwardhan is now with Hughes Network Systems, 11717 Exploration Lane, Germantown, MD 20876. S. G. Skaggs is now with Avant!, Physical Verification Product Line, 1101 Slater Road Durham, North Carolina, 27703, U.S.A.

first order differential ( $I = CdV/dt$ ), and first order integral ( $I = L \int V.dt$ ) equations. At each coupling point, that is a shared node in circuit terms, a mathematical coupling is established using Kirchoff's current law (KCL), stating that the sum of the currents entering each node is equal to zero. There are elaborations to this procedure to accommodate more complex constitutive relations but, if at all possible, these are described by interconnections of primitives describing simpler, lower-order interactions. Microwave engineering is distinguished by the ever present effect of electrically significant spatial distributions of electromagnetic (EM) fields. The accurate simulation of these circuits requires an integration of EM and electrical circuit models.

There are three important reasons to simulate electronic components: to understand the physics of a complex system of interacting elements; to test new concepts; and to optimize designs. Millimeter-wave circuits are becoming ever more commercially and militarily viable and, coupled with large scale production, design practices must evolve to be more sophisticated in order to handle more complex relationships between constituent elements. Also, as the frequency of RF circuits extends beyond a gigahertz to tens and hundreds of gigahertz, wavelengths become large with respect to device and circuit dimensions and the three dimensional EM environment becomes more significant. If reliable, high yielding, optimized designs of microwave and millimeter-wave circuits are to be achieved, the interrelated effects of the EM field and the linear and nonlinear circuit elements must be self-consistently modeled. One approach is to incorporate the lumped element devices of the circuit into traditional EM simulations. The device and circuit element equations are inserted into a time stepping EM simulator such as finite difference time domain (FDTD) or Transmission Line Matrix (TLM) simulator [1–7]. Here the constitutive relations of the conventional circuit elements are embedded in the analysis grid of the FDTD or TLM method, and lumped elements are incorporated as equivalent current or voltage sources. Nonlinear effects are addressed by the predictor algorithm inherent in the FDTD or TLM methods. Where the interaction of charge carriers with the EM field are significant, it may become necessary

to solve the carrier transport equations self consistently with the EM equations. This technique is discussed in other papers in this special issue. An alternative approach is to incorporate the EM environment as part of the circuit and to use a conventional circuit solver to integrate the EM and electrical effects.

Many of the important early developments in microwave engineering were made possible when the EM environment was transformed into a circuit abstraction which captured the relevant physical behavior of the EM structure. A good example of this is the circuit-level modeling of coupled transmission lines. This has enabled the synthesis of circuits and systems which would otherwise have physical descriptions that would be too difficult to work with. Four particular developments exemplify the modeling procedure of transforming a distributed structure into a lumped circuit. The first of these is the modeling work undertaken for radar development during the Second World War. Marcuvitz's book in the Radiation Laboratory Series documented the results of part of this effort and showed how discontinuities in waveguide could be modeled by lumped element equivalents [8]. This work later continued at Brooklyn Polytechnic Institute. The second work that had a tremendous effect on a generation of microwave engineers is Collin's *Foundation of Microwave Engineering* book which presented a formalism for treating distributed structures as circuit elements [9]. A third example is the pioneering work of Eisenhart and Khan [10] which presented an approach to modeling waveguide-based structures as circuit elements. In this work it was shown that quite sophisticated and accurate models could be developed for a three-dimensional waveguide system. This model has been used extensively in the design of post-mounted components, and the model developed is compatible with simple nonlinear circuit simulation [11]. The ramification of this work extends beyond waveguide circuits. The key concept introduced is that a structure that can support multiple EM modes can be described by a circuit with defined coupling between the modes. Each mode is represented by its own equivalent circuit. Thus a system that is generally considered as supporting incoherent components (a multimode system) can be modeled as a deterministic structure as required in the circuit modeling paradigm. Another important development which combines EM modeling with circuit descriptions is the segmentation approach introduced by Gupta and summarized recently [12]. In this segmentation (or diakoptic) approach a structure is partitioned into smaller parts and each part is characterized electromagnetically. Then these characterizations are combined using concepts based on network theory to yield the overall response of the circuit. One result of the segmentation approach is that the computational burden becomes manageable and the structure can be partially redefined and earlier characterizations of the unchanged parts reused. Another way to integrate the EM effects into the electrical circuit is by representing the EM environment (generally transmission lines and coupled transmission line structures) as large LRC networks or by equivalent pole-zero descriptions (rational transfer func-

tions). This technique has been successfully used to model signal propagation in high speed digital circuits [13], but it has problems modeling large spatially distributed structures, especially when the circuit dimensions are on the order of a wavelength or more.

From the early days commercial microwave circuit simulators supported an alternative technique based on the incorporation of any device or simple circuit model that could be described by port-based network parameters. Generally these device and circuit models were linear models specified by measured or derived scattering parameters at a number of discrete frequencies. The microwave circuit simulators were port-based, without the capability of specifying a reference node. At the same time, major advances were made in nodal-based electrical circuit modeling using very robust predictor-corrector algorithms. This provided the capability of handle very large, complex circuits and to model transient effects in circuits consisting of non-linear devices. Another technique for integrating the EM environment into a circuit simulator is to embody the linear EM response of circuit structures as a port-based scattering model inserted into a nodal-based electrical circuit model. This technique has the advantages that the linear EM part of the structure only need be solved once per frequency, and that it can utilize the large quantity of theoretical and method development already applied to the electrical simulation. This paper focuses on this technique and on the new conceptual framework necessary for its implementation.

One fundamental issue that arises in modeling electrically large systems in a circuit representation is the assignment of system ground. Currently circuit simulators use a nodal approach in which voltages are assigned to nodes and each of these voltages is referred to a common reference point commonly called ground. In a spatially distributed system, a common reference point cannot always be defined as the (electrically significant) spatial separation of a node and its reference point cannot be tolerated. If the separation is an appreciable fraction of a wavelength, it is not possible to uniquely define voltage. Developing a circuit simulation strategy that copes with this problem is a major topic of this paper.

Thermal effects can have major effects on microwave circuits, particularly when they include densely packed arrays of power devices, because high temperatures degrade the performance of semiconductor devices. Real microwave circuits are finite, with boundaries and internal components which have varying thermal properties and a granular distribution of active devices which act as thermal sources. This causes a nonuniform temperature distribution on the scale of the devices. In addition to the simple degradation in device performance with high temperatures, these nonuniformities can significantly affect the way the devices interact with each other, changing phase relationships and the character of radiated EM wave fronts. On a finer scale, each device also has finite boundaries and an irregular internal structure which have varying thermal properties, with the fingers of the device acting as thermal sources. This results in a temperature nonuniformity

on a finer scale, with the distances between device fingers on the order of microns or tens of microns. The temperature nonuniformity can strongly affect the way the internal parts of the device perform and interact, and therefore the overall device performance [14]. To understand the circuit function under real power conditions requires an ability to model the temporal nature of the thermal effects. The larger scale temperature profile has a relatively long time scale for changes in response to changes in the electrical circuit, making it feasible to decouple the thermal model from the electrical model. On the finer spatial scale, however, the temperature changes can occur on a sufficiently fast time scale to modulate the circuit characteristics at frequencies of system significance. The simulation of these effects requires a self-consistent integration of thermal and electrical models.

In this paper the global modeling of distributed microwave circuits, integrating EM, electrical circuit, and thermal modeling, is discussed. The spatial, or quasi-optical, power combiner is selected as an example to illustrate the features of the model because this combiner represents an extremely difficult circuit: densely packed electrical devices, spatially distributed over many wavelengths, where the EM field–device interactions are absolutely critical to the circuit operation. A brief description of the spatial power combiner is provided next to introduce the problems in implementing the model. A strategy is discussed for integrating the effects of EM structures into an electrical circuit model, then details of the circuit model are described. The integrated model is applied to the example of the grid amplifier spatial power combiner, with experimental results compared with the steady-state nonlinear circuit/EM analysis. An overall strategy is finally presented for how to integrate a finely resolved thermal model with the electrical circuit model.

## II. SPATIAL POWER COMBINERS

A continuing issue at microwave and higher frequencies is the development of high power solid-state sources. This is an enabling technology for a variety of military and commercial systems and, as history reminds us, of hitherto unimagined applications. Given the current state of maturity of microwave integrated circuit (MMIC) technology, the quest to produce high powers from solid state devices requires the investigation of novel semiconductor materials and of power combining architectures. In conjunction with improvements in the power handling capability of devices, the ability to combine powers from a multitude of devices is critical. An interesting novel power combining architecture is the spatial power combiner [15, 16], a generic but representative example of which is shown in Fig. 1. The spatial power combining architecture here is a two stage system with each stage consisting of a planar array of unit amplifiers each with its own input and output antennas. One proposed array is the grid amplifier shown in Fig. 2. Shown is an array of  $2 \times 2$  unit cells but actual arrays can be  $10 \times 10$  or larger. In Fig. 1 a waveguide horn spreads the vertically polarized energy from an input waveguide over a

surface that could be several wavelengths on a side. This spatially distributed signal impacts the array of amplifiers. The incident energy is then captured by the vertical grid structure acting as an antenna. The output function is implemented by the horizontal structure acting as an antenna. Thus the output from the individual amplifiers is combined in space to produce a single coherent output beam. In this example the input to the array is distributed spatially as well. The central concept of spatial power combiners is to radiate power from each active device into a propagating mode which is combined with the signals from other devices achieved without the generation of a backward propagating component.

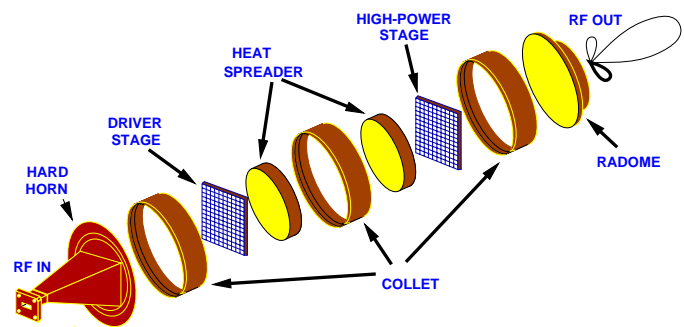

Fig. 1. A three dimensional transmission-mode spatially distributed power combining amplifier system.

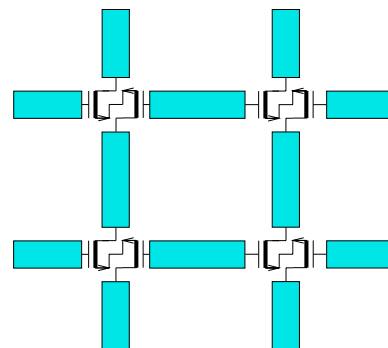

Fig. 2. A grid amplifier stage with active devices located at the intersection of the grid.

## III. GLOBAL MODELING STRATEGY

This paper describes a modeling strategy that allows a port-based EM model to be integrated with a nodal electrical circuit model in a natural manner that can also be used for integrating a thermal model. In an early approach two-port and three-port models of regular EM structures such as transmission lines or transmission line junctions were converted to nodal descriptions by setting one of the port terminals, at each and every port, to a global reference node. However nodal circuits have no sense of spatial extent. Such a global reference node cannot adequately describe the EM relationships between these port terminals, which can be spatially separated by electromagnetically significant distances in the actual EM structure. EM

models relying on such a global reference node concept cannot accurately treat large, multi-port structures. This paper presents a model development based on a new concept of local reference nodes (LRN's). The LRN concept enables the conversion of a port-based model to a node-based model which can be used in a general purpose circuit simulator after modifications to the way the nodal admittance matrix is treated.

Fig. 3 illustrates the model integration concept. In this circuit-oriented approach the high-level circuit abstraction is retained, and the results of EM analysis of the spatially distributed circuit are incorporated into the circuit framework [17–23]. A Method of Moments (MoM) EM analysis results in a matrix equation relating the voltages and currents in the EM structure, which is inverted to obtain the admittance matrix. The LRN concept allows this matrix to be combined with the matrix relating currents and voltages in the nodal circuit model of the linear part of the electrical circuit, resulting in a single matrix representing the linear network (see Fig. 3). Although these matrices can be extremely large, they can be mathematically reduced to much smaller matrices relating currents and voltages only at the points of the electrical connection to the nonlinear network. This process of inversion, combination, and reduction only needs to be performed once for each frequency of interest. The currents and voltages in the nonlinear network are then iteratively solved under the constraint of the matrix representing the linear network. For a steady-state solution, a harmonic balance algorithm is used, which directly employs the linear network matrix evaluated at one or a few discrete frequencies. For a transient solution, the linear network matrix is Fourier transformed to obtain the multi-terminal impulse response function, which is convolved with the nonlinear network response during its time domain solution. The structure of the overall model easily incorporates equations which can be expressed in terms of state variables in an admittance matrix format. In this manner a thermal model, expressed in terms of temperatures and heat conduction, can be integrated with the EM and electrical circuit model. This process will be described in more detail in following sections.

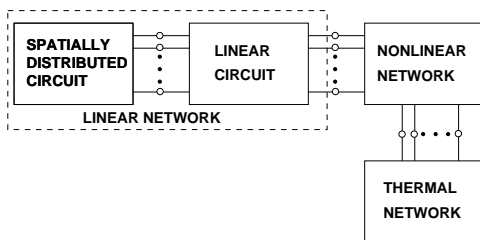

Fig. 3. Partitioning of a system into spatially distributed, linear circuit, nonlinear network, and thermal parts.

## IV. CIRCUIT MODELING

### A. Reference Nodes

Circuit theory has evolved to include a common reference node to which all voltages in a circuit are referred. How-

ever it is generally not feasible to define nodal voltages, or a single reference point, in a spatially distributed system. Microstrip networks are examples of distributed structures for which reasonable approximations have been made so that they can be treated as elements in conventional circuit simulators. A microstrip transmission line segment is shown in Fig. 4 with the conventionally accepted definition shown for the node voltages at the ends of the line. In the common approach the voltages  $V_1$  and  $V_2$  are determined as the integral of the electric field from the strip to the ground plane using the shortest paths — defined by the vertical arrows. However, an absurd “value” for  $V_2$  would be obtained if the integral were to be performed along the dashed line. So, the common approach treats the ground plane itself as a global reference point (common ground) even though this implies, and requires, that charges can instantaneously redistribute on the ground plane. While this has proved to be a successful modeling approach for microwave microstrip circuits which are generally arranged as cascaded stages, limitations are becoming evident in the modeling of strip-like distribution networks in high speed digital systems. In these systems it has become necessary to model the ground plane as a network of resistors and inductors [13]. An alternative approach is based on the concept of local reference groups (LRG's) and LRN's, as proposed in this paper.

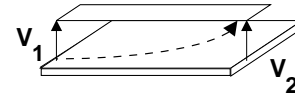

Fig. 4. A two port microstrip transmission line.

Consider the array shown in Fig. 2. This structure has nonlinear devices embedded in a structure that can only be characterized using EM modeling. The active devices in Fig. 2 are separated from each other by a distance of around a half wavelength and so the node voltages at each transistor pair can only be referenced locally and so the nodes form an LRG. An LRG is a group of nodes that are sufficiently close together that they can be referenced to an LRN without error of electrical significance. Thus it is only possible to define LRN's — one for each LRG — and not a single global reference node. Here there are four LRG's as shown in Fig. 5, and four LRN's. The LRN could be the common emitter connection but any node in the LRG could have been chosen. To recap the issue here: a single common reference node for this large circuit implies that the “nodal” voltages in one LRG have a specific voltage relationship with the “nodal” voltages in another LRG. Since the electric field is not conservative (the integral of the time-varying electric field from one point to another is dependent on the path taken) in this spatially distributed system, voltage has no meaning when referred over a large distance.

### B. Nodal Admittance Analysis

In nodal admittance analysis the current-voltage relationship of individual elements are combined with KCL at

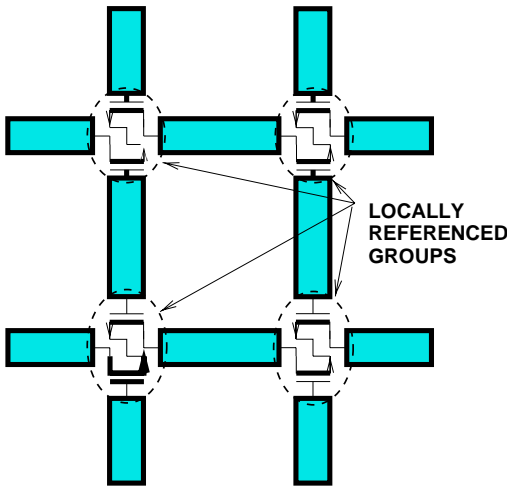

Fig. 5. Details of a quasi-optical grid array showing the locally referenced groups.

each node to yield a matrix that enables current in elements to be expressed as a nodal admittance matrix multiplied by a vector of node voltages. Modified nodal admittance (MNA) analysis was developed to handle elements that do not have admittance descriptions. For these offending elements additional equations become additional rows and columns in the matrix system of equations (the MNA matrix). A similar approach can be followed for handling the EM elements. The process is a little more complicated as now, instead of imposing additional constraints, constraints must be eliminated. There must not be any specific relationship between the node voltages in one LRG and the node voltages in another LRG. Using the conventional formulation of the nodal admittance matrix, specific relations between the node voltages of two LRG's are erroneously imposed. This is shown in Fig. 6(a). The conventional formulation, applied to the electrical circuits, employs a common ground as a global reference node. The difference between voltages at different circuit nodes have a unique physical meaning. In EM structures represented using the LRN formulation, only the voltage differences within an LRG are unique and have physical meaning. This is not true for voltage differences between nodes located in different LRG's. The LRG concept [24], based on the earlier compression matrix approach [17], removes the unnecessary constraints from the MNA. Rather than incorporating additional constitutive relations in the MNA, the LRG concept changes the way the port-based parameters (obtained from EM analysis or even network analyzer measurements) are used [24,25]. Fig. 6(b) shows the circuit analysis model for a spatially distributed structure with the grid amplifier of Fig. 5 used as a specific example. The LRN's are indicated by the diamond symbol, contrasted with the inverted triangle symbol used to represent the conventional global reference node. Following matrix reduction the model of the spatially distributed circuit and the linear circuit (e.g. parasitics) collapses to that shown in Fig. 6(c) and each LRN is at the interface with the nonlinear network or active device. This is fully compatible with using state variables

to describe the state of the nonlinear network. In a conventional circuit there is only one reference node (commonly ground). Then KCL is applied to the currents at each node of the circuit. The global reference node introduces one additional redundant row in the indefinite form of the MNA matrix. With the LRN concept, KCL is applied to one locally referenced group at a time. The LRN's are not electrically connected and so KCL applied to each of the, say  $M$ , LRG's results in  $M$  redundant rows and columns in the MNA matrix. This allows the voltages in different LRG's to be floating with respect to each other. The changes required in a circuit simulator is essentially one of book keeping [25]. This is a modification to standard nodal admittance analysis and is termed locally referenced MNA (LRMNA).

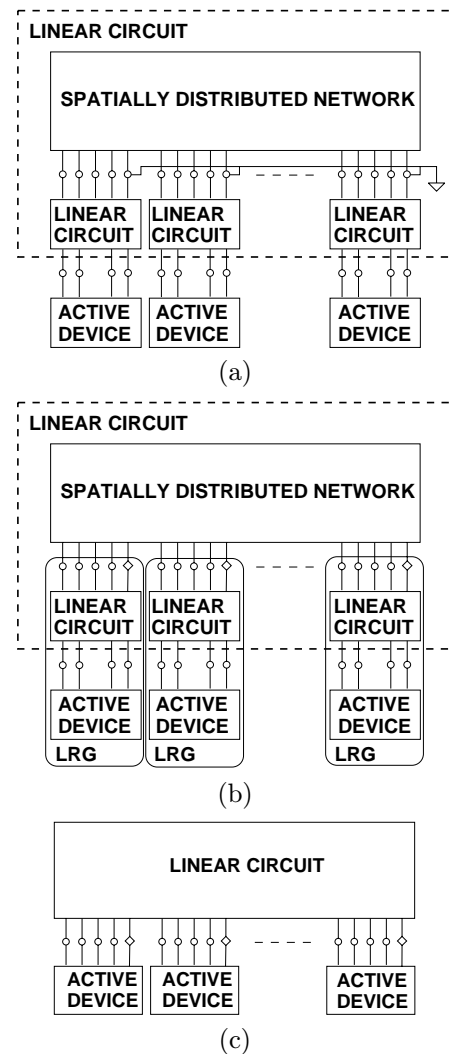

Fig. 6. Circuit model of a circuit with a spatially distributed network: (a) with a global reference node; (b) with LRN's; and (c) reduced network with LRN's.

## V. ELECTROMAGNETIC-CIRCUIT INTERFACE

The challenge in modeling the electromagnetic-circuit interface is to use quantities that have physical meaning in both the EM and circuit domains. As will be shown be-

low, the common concept is that of port voltages and port currents. Differential ports are the natural ports extracted by most EM field simulators. These are the artificial computational ports between the elements which discretize the EM surface. Sometimes these ports correspond to the real physical ports (as for the structure shown in Fig. 2). If the desired ports are not in a differential configuration, they must be derived. Derived ports must be computationally established where, for example, a ground plane is not explicitly incorporated in the EM analysis but instead incorporated into the Green's function of the structure using image theory.

### A. Differential Ports

In EM analysis using the Method of Moments (MoM) basis functions (typically pulse or half sinusoid) are used to discretize the surface current density. If appropriate choices are made, the coefficient of a basis function is the current at the junction of two geometric cells. The tangential field at the conductive layer is represented by the voltage between two cells. The voltage and current at the interface of two cells are quite naturally port voltage and current respectively. The differential ports for one LRG of the grid amplifier array is shown in Fig. 7. In MoM the relationship between the current-like and voltage quantities is derived using Green's functions and the matrix that results is called an MoM impedance matrix,  $\mathbf{Z}_{MoM}$ . Thus

$$\mathbf{V}_P = \mathbf{Z}_{MoM} \mathbf{I}_P \quad (1)$$

where  $\mathbf{V}_P$  is the vector of port voltages at every inter-cell boundary and  $\mathbf{I}_P$  is the vector of port currents at these boundaries. Inverting

$$\mathbf{I}_P = \mathbf{Y}_{MoM} \mathbf{V}_P \quad (2)$$

and the MoM Admittance matrix  $\mathbf{Y}_{MoM} = \mathbf{Z}_{MoM}^{-1}$ . Where the conductive layer is continuous, the port (or delta-gap) voltages are zero. At breaks in the conductive layer, for example where active devices would be located, the port voltages are retained as variables and the ports are referred to as circuit ports. With the circuit ports assigned first, all of the elements of  $\mathbf{V}_P$  following the initial elements associated with the circuit ports, are zero. Then the port-based  $Y$  parameters (at the nodes to be connected to the conventional circuit) will be the upper left-hand submatrix of  $\mathbf{Y}_{MoM}$ . For the single LRG case shown in Fig. 7, the submatrix is a  $4 \times 4$  matrix.

### B. Derived Ports

In modeling a structure with more complex active electrical components, such as MMIC's, circuit ports must be established at each terminal of each MMIC and referenced to the ground plane of the MMIC using the shortest path to the metal sheets. This shortest path establishes the position of the LRN. One terminal of each circuit port is a terminal of one of the differential ports (described above) and the other terminal, the LRN, is not. In MoM analyses the ground plane is accounted for using a Green's function

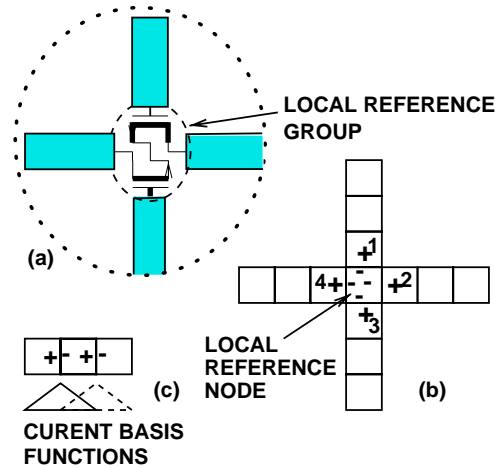

Fig. 7. Definition of differential ports: (a) a locally referenced group for a portion of the grid amplifier; (b) geometric cells used in MOM analysis; and (c) current basis functions in relation to the geometric cells.

developed using image theory so that the ground plane does not need to be discretized. Thus the circuit port here must be synthesized as not all of the terminals were part of the EM analysis. The derived ports are of two types: inner ports and external ports.

Fig. 8 is a diagram of a MMIC and circuitry inside a metal box. Shown inside the package is transmission line circuitry which must be included in the EM analysis while the MMIC is modeled by nonlinear circuit model. EM effects internal to the MMIC would be incorporated in the circuit model of the MMIC. The ports at the cavity wall (e.g. flanges) are the external derived ports each of which is referenced to the ground plane at that wall. The interface between the MMIC itself and the feeding transmission line circuitry inside the package is an inner derived port.

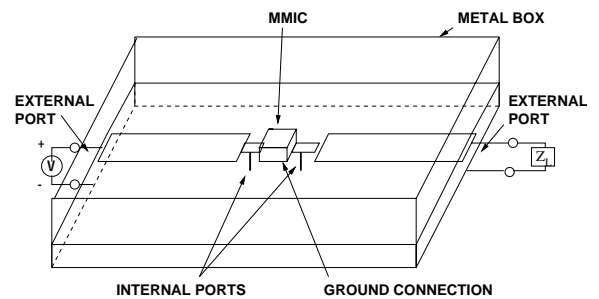

Fig. 8. Internal and external derived ports.

#### B.1 External Derived Ports

The derived port voltage and current at an external port can be obtained using the half basis technique presented by Eleftheriades and Mosig [22], see Fig. 9. The half basis function technique works when the external port is terminated in an electrical wall as it is in the cavity structure shown in Fig. 8.

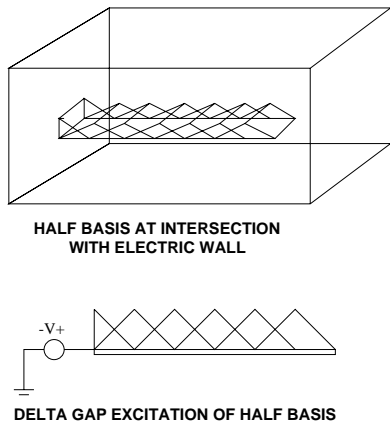

Fig. 9. The half basis function technique for defining an external derived port.

## B.2 Inner Derived Ports

Building on the above half basis function idea, Zhu *et al.* computed external port parameters for unbounded structures [23]. In the Zhu paper, the authors use the segmentation approach to partition the feeding lines from the rest of the circuit. In effect these feeding lines are terminated in an introduced electrical wall and half basis functions are used. Then an image of the line is used to compute the inner port parameters. However this approach alters the physical behavior of the circuit. Introduction of a vertical current element (basis function) in the position of the circuit port would, conceivably, be one way of defining the inner circuit port in the MoM formulation. However, more generally, it must be derived using the differential ports that are immediately available in MoM methods. The approach used mimics measurements in that additional calculations of modified structures are used to establish what is in effect a reference plane. In one approach EM modeling enables the standing wave parameters to be determined. From this the reflection coefficient and hence the input impedance are calculated. Alternatively additional elements can be inserted between, say, two inner ports to perform the equivalent of a line-reflect-match (LRM) calibration.

## VI. STEADY-STATE CASE STUDY: A GRID AMPLIFIER

The global modeling concept is illustrated here by simulating the quasi-optical grid amplifier shown in Fig. 10 using harmonic balance analysis. The amplifier has input and output horns and a  $2 \times 2$  array of unit amplifiers. The input horn serves to distribute power over the array and the output horn collects power radiated by the array. The full circuit-level model of this structure must include the attachments for bias circuitry as shown in Fig. 11. The bias inductors were realized using chip inductors and these were arranged in a symmetrical pattern which was found to be important to maintain a centered radiated beam. (This was determined experimentally and simulated). The measured and simulated nonlinear performance at approximately a 1 dB gain compression level is shown in Fig. 12.

Further details of this simulation are available [26].

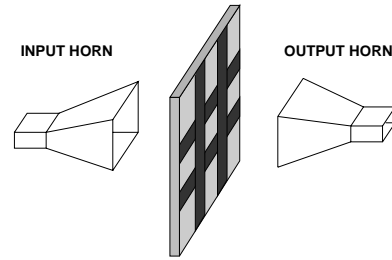

Fig. 10. Measurement setup for the grid amplifier.

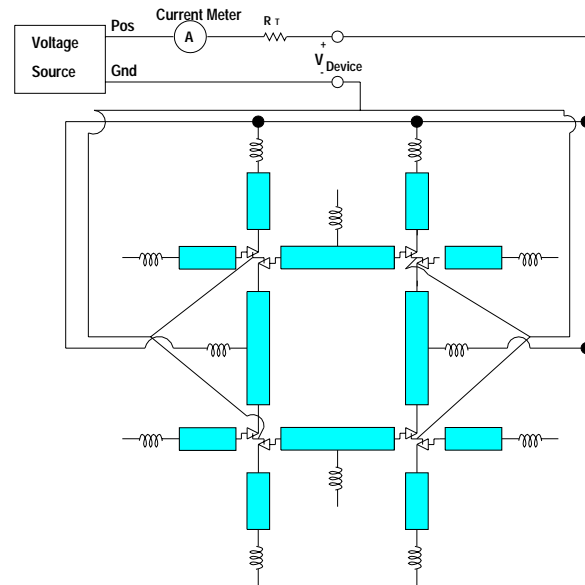

Fig. 11. Circuit-level schematic of a  $2 \times 2$  grid amplifier.

## VII. THERMAL CIRCUIT INTEGRATION

In order to model important circuit consequences of thermal effects, a thermal analysis must be integrated with EM/electrical circuit analysis. This section discusses a possible approach. Fortunately, the concept of LRG's facilitates the integration of thermal modeling in the circuit simulator. The structure of an integrated electro-thermal element is outlined in Fig. 13. Here the active device generates heat and with the local thermal model injects heat into the rest of the thermal network. The thermal ground is taken as 0 K, naturally, and is simply treated in the circuit simulator as an LRN. Thus the entire thermal network (which could be a separate thermal simulator) is treated by the circuit simulator as a single LRG. At the interface between the circuit and the thermal simulators are temperature,  $T$ 's, and heat flow,  $H$ 's, variables. Analysis proceeds with  $T$  as state variables and the thermal error function is  $\Sigma H = 0$  at each thermal node. (This is analogous to the electrical simulation which could — but is not constrained to — use voltages as state variables and an error function  $\Sigma I = 0$  at each electrical node.) The zeroes of this function (together with the other error functions) are found by adjusting the state variables.

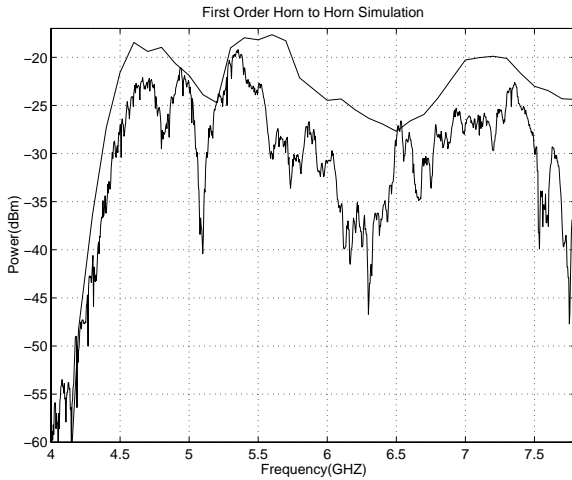

Fig. 12. Power output for 2x2 grid amplifier system: jagged line, measurement; solid line, simulation.

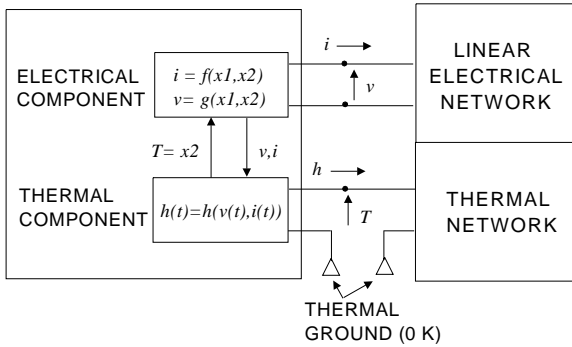

Fig. 13. An electrothermal element connected to linear and thermal networks.

## VIII. CONCLUSION

The circuit-level modeling of high frequency, electrically large, systems has been achieved by integrating electromagnetic field analysis with circuit characterization. This was possible by combining the local reference node concept with state variable based simulation. Simulation results were compared with experimental measurements on a large spatial power combiner circuit. A methodology to integrate a thermal model with EM/electrical circuit model in a consistent manner was presented. With all mixed domain analyses, considerable attention must be paid to the interface to ensure that the connection of different solution domains is physically correct. Development of the circuit-centric approach takes longer than a field-centric approach in which circuit elements are incorporated in the circuit description. However the circuit abstraction was the focus of our approach as we believe that eventually this provides the most flexibility and utility because it builds on a substantial body of circuit theory, and enables optimization, oscillator analysis, steady-state harmonic balance analysis, and sophisticated device models to be reused.

The concepts presented here have broad applicability. One example is in the modeling of the electrical performance of electronic packaging. It is common to experi-

mentally characterize such packages using network analyzer measurements. This produces a multi-port network model which can be transformed to port-based  $Y$  parameters. Before these can be used in a circuit simulator they must be transformed to node-based (or nodal)  $Y$  parameters. Even then, modification is required to the internal simulator algorithm to accommodate local reference nodes. In general each port has two nodes, one of which is a local reference node. However ports would generally be grouped according to their physical proximity so that the number of LRN's is less than the number of ports.

## REFERENCES

- [1] S. M. S. Imtiaz, and S. M. El-Ghazaly, "Global modeling of millimeter-wave circuits: electromagnetic simulation of amplifiers," *IEEE Trans. on Microwave Theory and Tech.*, Vol 45, Dec. 1997, pp. 2208–2217.
- [2] C.-N. Kuo, R.-B. Wu, B. Houshmand, and T. Itoh, "Modeling of microwave active devices using the FDTD analysis based on the voltage-source approach," *IEEE Microwave Guided Wave Lett.*, Vol. 6, May 1996, pp. 199–201.
- [3] L. Cascio; W. J. R. Hofer, "Modification of the 3D-TLM scattering matrix to model nonlinear devices in graded and heterogeneous regions," *1998 IEEE MTT-S Int. Microwave Symp. Dig.*, Vol. 2, June 1998, pp. 897–900.
- [4] P. Ciampolini, P. Mezzanotte, L. Roselli and R. Sorrentino, "Accurate and efficient circuit simulation with lumped-element FDTD technique," *IEEE Trans. Microwave Theory Techn.*, Vol. 44, Dec. 1996, pp. 2207–2215.
- [5] V. A. Thomas, M. E. Jones, M. Piket-May, A. Taflove and E. Harrigan, "The use of SPICE lumped circuits as sub-grid models for FDTD analysis," *IEEE Trans. Microwave Theory and Techn.*, Vol. 45, May 1994, pp. 141–143.
- [6] C.-N. Kuo, B. Houshmand, and T. Itoh, "Full-wave analysis of packaged microwave circuits with active and nonlinear devices: an FDTD approach," *IEEE Trans. Microwave Theory and Techn.*, Vol 45, May 1997, pp. 819–826.
- [7] S. M. El-Ghazaly and T. Itoh, "Electromagnetic interfacing of semiconductor devices and circuits," *1997 IEEE MTT-S Int. Microwave Symp. Dig.*, Vol. 1, June 1997, pp. 151–154.
- [8] N. Marcuvitz, *Waveguide Handbook*. New York: McGraw Hill, Radiation Laboratory series, No. 10, 1951
- [9] R. E. Collin, *Foundations for Microwave Engineering*, Tokyo: McGraw-Hill, 1966
- [10] R. L. Eisenhart and P. J. Khan, "Theoretical and experimental analysis of a waveguide mounting structure," *IEEE Trans. Microwave Theory Tech.* Vol. 19, Aug. 1971, pp. 706–719
- [11] R. G. Hicks and P. J. Khan, "Numerical analysis of nonlinear solid-state device excitation in microwave circuits," *IEEE Trans. Microwave Theory Tech.*, Vol. 30, March 1982, pp. 251–259.
- [12] K. C. Gupta, "Emerging trends in millimeter-wave CAD," *IEEE Trans. Microwave Theory Tech.*, Vol. 46, April 1998, pp. 475–483.
- [13] A. E. Ruehli and H. Heeb "Circuit models for three-dimensional geometries including dielectrics" *IEEE Trans. Microwave Theory Tech.*, Vol. 40, July 1992, pp.
- [14] C. M. Snowden, "Large-signal microwave characterization of AlGaAs/GaAs HBT's based on a physics-based electrothermal model," *IEEE Trans. Microwave Theory and Techn.*, Vol. 45, Jan. 1996, pp. 58–71.
- [15] T. Ivanov, S. Ortiz, A. Mortazawi, E. Schlecht, and J. Hubert, "A passive double-layer microstrip array for the construction of millimeter-wave spatial power-combining amplifiers," *IEEE Microwave and Guided Wave Letters*, Vol. 7, Nov. 1997, pp. 365–367.
- [16] M. P. De Lisis, S. W. Duncan, D.-W. Tu, C.-M. Liu, A. Moussessian, J. J. Rosenberg, and D. B. Rutledge, "Modeling and performance of a 100-element pHEMT grid amplifier," *IEEE Trans. Microwave Theory Tech.*, Vol. 44, Dec. 1996, pp. 2136–2144.
- [17] J. Kunisch and I. Wolff, "Steady-state analysis of nonlinear forced and autonomous microwave circuits using the compression approach," *Int. J. of Microwave and Millimeter-Wave Computer-Aided Engin.*, Vol. 5, No. 4, 1995, pp. 241–225.



- [18] T. W. Nuteson, H. Hwang, M. B. Steer, K. Naishadham, J. W. Mink, and J. F. Harvey, "Analysis of finite grid structures with lenses in quasi-optical systems," *IEEE Trans. Microwave Theory Techn.*, May 1997, pp. 666–672.
- [19] T. W. Nuteson, G. P. Monahan, M. B. Steer, K. Naishadham, J. W. Mink, K. Kojucharoff and J. Harvey, "Full-wave analysis of quasi-optical structures," *IEEE Trans. Microwave Theory Techn.*, May 1996, pp. 701–710.
- [20] R. P. Parrikar and K. C. Gupta, "Multiport network model for CAD of electromagnetically-coupled microstrip patch antennas," *Proc. 1996 IEEE Antennas and Propagation Society Int. Symp. Dig.*, Vol. 2, 1996, pp. 1058–1061.
- [21] E. Larique, S. Mons, D. Baillargeat, S. Verdeyme, M. Subourg, P. Guillon, and R. Quere, "Electromagnetic analysis for microwave FET modeling," *IEEE Microwave and Guided Wave Letters*, Vol. 8, Jan. 1998, pp. 41–43.
- [22] G. V. Eleftheriades, and J. R. Mosig, "On the network characterization of planar passive circuits using the method of moments," *IEEE Trans. on Microwave Theory and Techn.*, Vol. 44 No 3, Mar. 1996, pp 438–445.
- [23] L. Zhu, and K. Wu, "Characterization of unbounded multiport microstrip passive circuits using an explicit network-based method of moments," *IEEE Trans. on Microwave Theory and Techn.*, Vol. 45, Dec. 1997, pp 2114–2124.
- [24] A. I. Khalil and M. B. Steer, "Circuit theory for spatially distributed microwave circuits," *IEEE Trans. Microwave Theory and Techn.*, Oct. 1998, pp. 1500–1502.
- [25] C. E. Christoffersen and M. B. Steer, "Implementation of the local reference node concept for spatially distributed circuits," *Int. J. Microwave and Millimeter-Wave Engin.*, In Press.
- [26] M. A. Summers, C. E. Christoffersen, A. I. Khalil, S. Nakazawa, T. W. Nuteson, M. B. Steer and J. W. Mink, "An integrated electromagnetic and nonlinear circuit simulation environment for spatial power combining systems," *1998 IEEE MTT-S Int. Microwave Symp. Dig.*, June 1998, pp. 1473–1476.

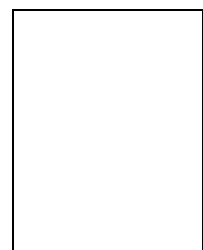

**Mostafa N. Abdulla** (S'97) Mostafa N. Abdulla (S'97) was born in Cairo, Egypt, in February 1970. He received the B.S.E.E. and M.S.E.E. degrees from Ain Shams University, Cairo, Egypt, in 1992 and 1996, respectively. From 1992 to 1996 he was Lecturer in the Department of Electrical Engineering, Ain Shams University, where his research dealt with antennas and microwave circuits. Presently, he is a Research Assistant in the Electrical and Computer Engineering Department at North

Carolina State University where he is pursuing the Ph.D degree. His current research interest include analysis, modeling and design of microwave and millimeter-wave devices and circuits. He is a member of the Phi Kappa Phi Society.

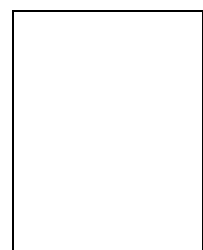

**Carlos E. Christoffersen** ('91) was born in Argentina in 1968. He received the Electronic Engineer degree at the National University of Rosario, Argentina in 1993. From 1993 to 1995 he was research fellow of the National Research Council of Argentina (CONICET). He received the M.S. degree in electrical engineering in 1998 from North Carolina State University. Currently he is pursuing his Ph.D. degree at the same university. Since 1996, he has been with the Department of Electrical and Computer

Engineering as a research assistant. His research interests include computer aided analysis of circuits, analog, RF and microwave circuit design.

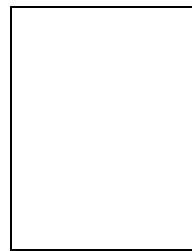

**Hector M. Gutierrez** (S'97—M'98) was born and raised in Lima, Peru, where he received the B.Sc. Degree in Applied Mathematics from Universidad Cayetano Heredia in 1989, and the B.Sc. Degree in Mechanical Engineering from the Pontificia Universidad Catolica in 1991. After working for two years as Lecturer at the Department of Mathematics and Physics, Universidad Cayetano Heredia, Lima, he moved to North Carolina State University, where he earned the M.Eng. Degree in Man-

ufacturing Systems Engineering in 1993, and the Ph.D. in Electrical Engineering in 1997. Since 1997 he has been with the Center for Advanced Computing and Communication, North Carolina State University, developing behavioral models of nonlinear microwave amplifiers and simulation tools for modeling electro-thermal circuit interactions.

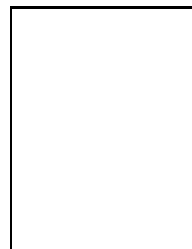

**James F. Harvey** (M'91) Dr. Harvey is currently a research program manager at the US Army Research Office, with primary responsibility for the fields of electromagnetics, antennas and antenna structures, innovative microwave and millimeter wave circuit integration, low power/minimum power system design, and landmine detection. His programs include a focus on small, multifrequency, multifunctional antennas for Army vehicles, radio propagation over complex terrain affecting data communications, new millimeter wave circuit integration techniques such as spatial power combining, micromachining, and advanced electromagnetic calculational techniques. His personal research interests are in the fields of quasi-optics and multiresolution analysis of electromagnetic structures.

**Patrick L. Heron** (S'91—M'94) received the B.S. degree, the M.S. degree, and there Ph.D. degree in electrical engineering from California State University Sacramento, University of Central Florida, and North Carolina State University, in 1983, 1987, and 1993 respectively. His work has included design and prototyping of remote sensing systems for geophysical, environmental, and defense applications. He has also developed paradigms for accurate estimation of integrated circuit interconnect parasitic capacitance. He currently designs integrated circuits for communications applications.

Photograph unavailable.

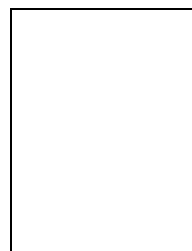

**Chris W. Hicks** (S'95) received the BS in electrical engineering from the University of South Carolina, Columbia, in 1985, M.S.E.E. degree from North Carolina A&T State University, Greensboro, in 1994, and is currently pursuing his Ph.D. degree from North Carolina State University, Raleigh. In 1985, he joined the Naval Air Warfare Center-Aircraft Division (NAWC-AD), in Patuxent River, MD. He currently works for the RF Sensors Branch where he performs research and development

for microwave and millimeter wave systems and devices. He is also a research assistant with the Electronics Research Laboratory, Department of Electrical and Computer Engineering, North Carolina State University where he performs research in two-dimensional spatial power combining and moment method simulations. Mr. Hicks was the recipient of full-time training fellowships from NAWC-AD to obtain his M.S.E.E. and Ph.D. degrees. His interests are microwave theory and measurement techniques, computational electromagnetics, and quasi-optic and spatial power combining.

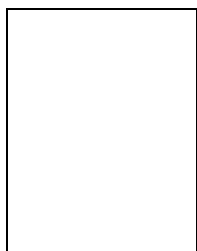

**Ahmed I. Khalil** was born in Cairo, Egypt, in 1969. He received the B.Sc. (with honors) and M.Sc. degrees from Cairo University, Egypt, both in electronics and communications engineering, in 1992 and 1996, respectively. From 1992 to 1996 he worked at Cairo University as a Teaching Assistant. While working towards his Ph.D. degree in electrical engineering at NCSU, he held a Research Assistantship with the Electronics Research Laboratory in the Department of Electrical and Computer

Engineering. Interests include numerical modeling of microwave passive and active circuits, quasi-optical power combining, and waveguide discontinuities. He is a member of the honor society Phi Kappa Phi.

**James W. Mink** (S'59—M'65—SM'81—F'91) for a photograph and biography, see p. 13 of the January 1999 issue of this TRANSACTIONS.

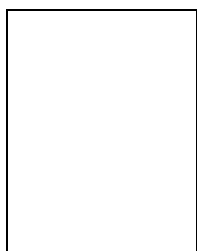

**Usman A. Mughal** (S'98) was born in Hawalli, Kuwait in, 1973. He received his B.S. degree in Computer Engineering (Summa Cum Laude) from North Carolina State University. While pursuing his B.S. degree he worked as a co-op for BNR, RTP, NC, in the spring of 1996 and Nortel, RTP, NC, in the summer of 1997. Currently, he is working towards his M.S. degree in Electrical Engineering as an R.A. with the Electronics Research Laboratory at NCSU.

In the summer of 1998, he worked as an intern at Cadence Design System, Inc. Cary, NC. His research interests include VLSI design, RF circuits, digital electronics, CAE tool development and international finance. He is an elected member of Phi Kappa Phi.

**Satoshi B. Nakazawa** (S'95) for a photograph and biography, see p. 13 of the January 1999 issue of this TRANSACTIONS.

**Todd W. Nutesson** (S'90—M'91) for a photograph and biography, see p. 13 of the January 1999 issue of this TRANSACTIONS.

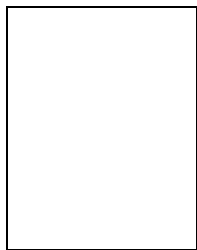

**Jae Patwardhan** Jae Patwardhan was born on 13th September 1973 in Pune, India. She received her Bachelors degree in Electronics and Telecommunications Engineering at the University of Pune, India in May 1995. She worked as a research assistant in the Electronics Research Laboratories at North Carolina State University and received her Masters in Electrical Engineering in May 1997. The focus of her research and thesis under the guidance of Dr Michael Steer was Modular Computer Aided

modeling of Quasi-Optic power combining systems. After completing her Masters in Electrical Engineering from North Carolina State University she has been working at Hughes Network Systems in their Wireless Networks Division. Her interests include wireless system standards like IS-136, IS-95, RF circuits, modular computer aided programming etc. She is a member of IEEE.

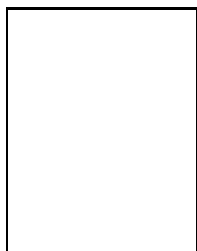

**Steven G. Skaggs** (S'85—M'96) received the Bachelor of Science degree in electrical engineering *summa cum laude* from North Carolina State University in 1989. In 1991, he received the Master of Science degree, also from North Carolina State University. From 1994 to 1995, he was employed by Compact Software in Paterson, New Jersey. Since August of 1995, he has been employed by Avant! Corporation. He is currently pursuing the PhD degree at North Carolina State University with an emphasis on

efficient simulation of large microwave circuits. His research interests include harmonic balance simulation, device modeling, and parameter extraction.

**Michael B. Steer** (S'76—M'78—SM'90—F'99) for a photograph and biography, see p. 13 of the January 1999 issue of this TRANSACTIONS.

**Mark A. Summers** (S'97—M'99) received the B.S. and M.S.E.E. degree from North Carolina State University, Raleigh in 1996 and 1997 respectively. In 1998 he joined the Analog-Mixed-Signal design group in Cadence Design Systems in Cary, NC. While pursuing his M.S.E.E he was a research assistant with the Electronics Research Laboratory, Department of Electrical and Computer Engineering, North Carolina State University. His interest include analog and RF circuit design.

Photograph unavailable.

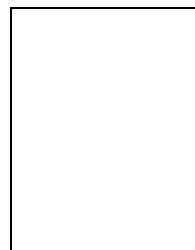

**Alexander B. Yakovlev** (S'95—M'98) was born in Ukraine on June 5, 1964. He received the Ph.D. degree in Radiophysics from the Institute of Radiophysics and Electronics, National Academy of Sciences, Ukraine, and the Ph.D. degree in Electrical Engineering from the University of Wisconsin-Milwaukee, USA, in 1992 and 1997, respectively. From 1992 to 1994, he was an Assistant Professor with the Department of Radiophysics at Dniepropetrovsk State University, Ukraine. During the period of his doctorate program from 1994 to 1997 he worked as a Research and Teaching Assistant in the Department of Electrical Engineering and Computer Science at the University of Wisconsin in Milwaukee. From 1997 to 1998 he worked as R&D Engineer in Ansoft Corporation/Compact Software Division, Paterson, NJ and in Ansoft Corporation, Pittsburgh, PA. He is currently a Research Associate with the Electrical and Computer Engineering Department at North Carolina State University, where is involved in the electromagnetic modeling of high-frequency interconnections for quasi-optical power combining. His research interests include mathematical methods in applied electromagnetics, modeling of IC elements and devices, theory of leaky waves, catastrophe and bifurcation theories. Dr. Yakovlev received the Young Scientist Award of URSI International Symposium on Electromagnetic Theory, Sydney, Australia, 1992, and the Young Scientist Award of International Symposium on Antennas and Propagation, Chiba, Japan, 1996.

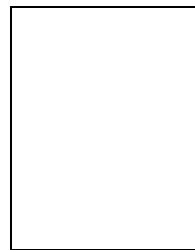

**Shunmin Wang** Shunmin Wang received the B.S. degree from Nanjing University of Science and Technology, China, in 1987, M.S. degree from Tianjin University, China, in 1990, both in Computer Engineering. Currently he is a Ph.D. student at North Carolina State University in Operations Research program, Raleigh, NC. From 1990 to 1997, he joined the Sixth Research Institute of China Ministry of Electrical Industry, and integrated several distributed control systems and data acquisition systems for 300 MW power plants. His current research interests include simulation and linear/nonlinear optimization.